

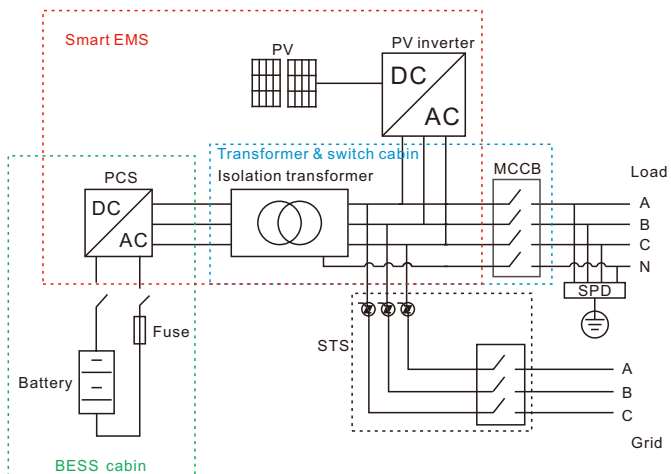

## Smart C&I BESS + Solar PV System



All-in-one design, integrated liquid cooling battery pack, battery management system BMS, energy management system EMS, modular PCS and fire protection system in one. The system is equipped with transformers and switchgear. The system can be combined with photovoltaic power generation to form a grid-tied solar with energy storage system. Multiple systems can be connected in parallel for flexible expansion. The system is suitable for a variety of applications such as, on-grid/off-grid solar energy and storage system, backup power supply, and solar-diesel-microgrid system.

# ZGE-CI-Z-186-372-S

Battery	
Configuration	1P416S
Number of Pack	8
Electrical	
Charging Current	140A
Discharging Current	140A
Rated Capacity	372.7kWh
Voltage Range	1164.8~1497.6V
Rated Voltage	1331.2V
Rated Power	186.3kW, 0.5P
Auxiliary Power	
Voltage Range	176~264V
Cooling Unit Power	Cooling: 3.1KW; Heating: 2.0KW
BMS Power	60W
Battery Cabinet	
Protection Grade	Battery: IP66; Control: IP55
Anticorossion	C5
Cooling Mode	Liquid Cooling
PCS	
Basic	
Rated Power	200kVA
Overload Capacity	Constant Operation@110%; 1 min@120%
Efficiency	Max. 99%
Power Response	<20ms
Charge/Dischargr Transfer	<50ms
DC	
Max DC Voltage	1500V
DC Voltage Range	1100~1500V

DC Voltage Range(100%load)	1100~1500V
AC	
Rated Voltage	750V
Rated Current	154A
Max Constant Current	169A
Voltage Range	-15%~+10%
Frequency	50/60±5Hz
THDi	<3%
Wiring Group	3/PE
General	
Altitude	-40~+60℃
Protection Grade	IP66
Noise	≤70dB
Cooling Mode	Air Forced Cooling
Communication	
Communication Port	RS485
Communication Protocol	Modbus-RTU;TCP-IP
Installation	
Dimensions (W*D*H)	1620*1350*2450mm
Weight	3895kg
Certificate	IEC62477, IEC61000, CEI-016, VDE4110, EN50549, IEC62619

## List of Equipment

NO.	Name	Recommended model/ Specifications	QTY	Remark
1	Energy Storage System Cabin	186kW/372kWh	-	See NO. 1.1 to 1.3 for details
1.1	Li-ion Battery	Adopting LFP battery, continuous charging/discharging multiplication rate $\leq 0.5C$ , including battery module, switch box, BMS system, etc.	1	
1.2	PCS	Rated power 186kW, output voltage AC750V, three-phase three-wire.	1	
1.3	Cabin	L*W*H: 1760*1500*2500mm, including temperature control system, fire protection system, power distribution system, heat dissipation duct and connecting cables between equipment in the box, IP66	1	
2	Transformer & Switch Cabin	Grid-connected voltage 220V	-	See NO. 2.1 to 2.3 for details
2.1	Transformer	Dry SCB12-200-0.75/0.22kVDyn11, rated capacity 200kVA	1	
2.2	400V Switch Cabin	220V, 630A	1	
2.3	Cabin	W*D*H: 1150 x 1900 x 2040mm, IP66	1	
3	EMS	-	1	
4	Solar Inverter	Configured based on the capacity requirements	-	Customer's scope of supply
5	PV Panels	Configured based on the capacity requirements	-	Customer's scope of supply

Battery System

PCS

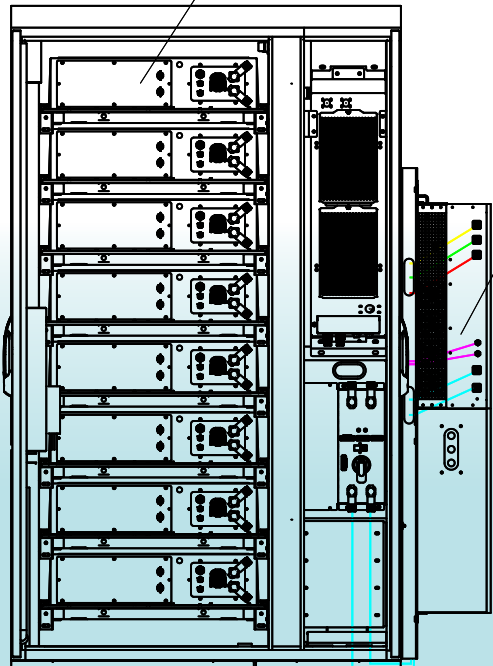

Transformer

Switch cabinet

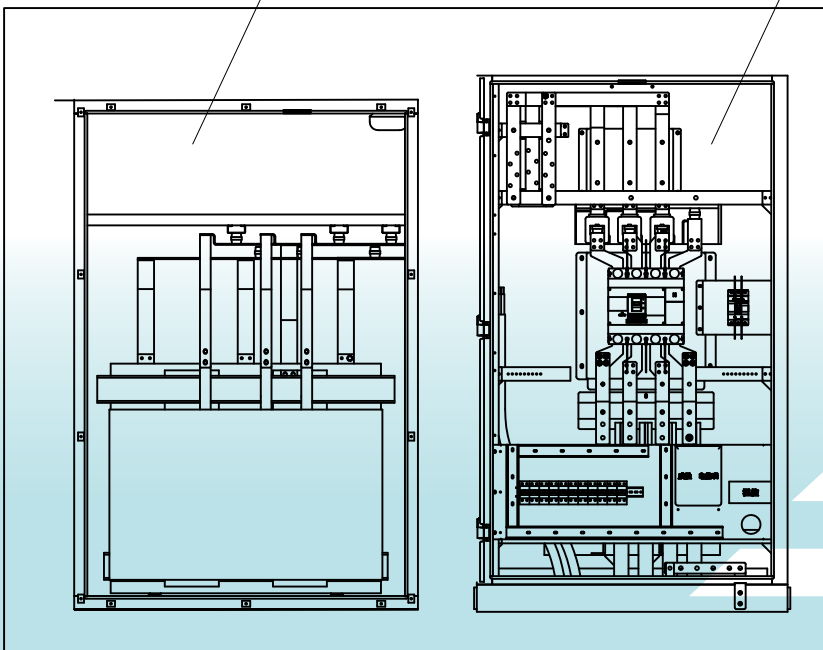

## Grid-connected scenario

A grid-connected BESS offers the ability to capture and store electrical energy when the demand is low and provide electricity when the demand is high. This ability allows the business to operate more efficiently and sustainably.

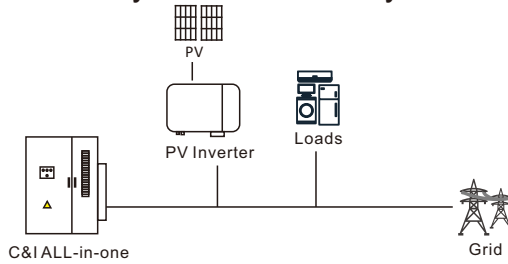

## Parallel connection scenario

The BESS connected in parallel allows for easier scalability, additional BESS can be added or removed without affecting the existing system. With the parallel connection, the system is able to have more flexibility in terms of system design and operation.

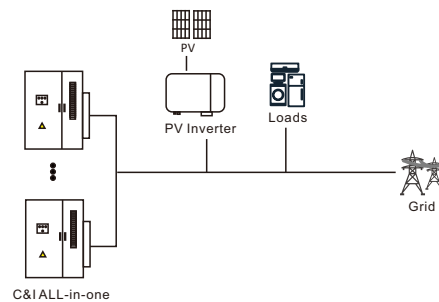

## Microgrid scenario

Combining with solar or diesel generator, the system can become a local energy production and distribution network that can function independently when there is no access to grid.

